



STEELBUILT
CURTAINWALL INFINITY™ SYSTEM

Architectural Specification Manual

STEELBUILT

CURTAINWALL INFINITY™ SYSTEM

STEELBUILT CURTAINWALL INFINITY™ SYSTEM

Now you can design what you envision, as limits are a thing of the past. The SteelBuilt Curtainwall Infinity™ System can use as a back mullion almost any type of structural member, from stainless steel to glulam beams. This allows architects and designers to use larger areas of glass, smaller frame profiles and wider free-spans than are possible with traditional aluminum curtainwall. This flexibility in design and material allows curtainwalls to be incorporated into a nearly limitless range of building types, designs, and performance requirements. SteelBuilt Curtainwall Infinity System helps inspire a whole new world of creativity.

For specifications, photographs and additional information contact:

TECHNICAL GLASS PRODUCTS

8107 Bracken Place SE
Snoqualmie, WA 98065

Office: 800.426.0279

Fax: 800.451.9857

E-mail: sales@tgpamerica.com

Web: tgpamerica.com

CSI-SPECIFICATION

Full copies of our CSI specifications can be downloaded from our Web site at tgpamerica.com/specs/ or obtained from our office.

This Architectural Specification Manual provides a summary of the specification, design and applications that can be achieved with SteelBuilt Curtainwall Infinity™ System. Many special finishes and components are available, please consult Technical Glass Products.

© 2012 Technical Glass Products. SteelBuilt Curtainwall Infinity is a trademark of Technical Glass Products. One Source. Many Solutions., and Technical Glass Products are registered trademarks of Technical Glass Products.

Introduction1

System Overview 2

Connection Options3

Reference Details - I-Beam 4

Reference Details - Tube5

Reference Details - T 6

Reference Details - TR 7

Reference Details - Framing Options 8

Reference Details - Horizontal Depth 9

Corner Options10-13

Mullion Profiles14-15

Alternate Perimeter16

Point Supported Glazing17

Cover Caps 18-20

LAWS AND BUILDING AND SAFETY CODES GOVERNING THE DESIGN AND USE OF GLAZED ENTRANCE, WINDOW, AND CURTAIN WALL PRODUCTS VARY WIDELY. TGP DOES NOT CONTROL THE SELECTION OF PRODUCT CONFIGURATIONS, OPERATING HARDWARE, OR GLAZING MATERIALS, AND ASSUMES NO RESPONSIBILITY THEREFOR.

Metric (SI) conversion figures are included throughout these details for reference. Numbers in parentheses () are millimeters unless otherwise noted.

The following metric (SI) units are found in these details:

- m – meter
- cm – centimeter
- mm – millimeter
- s – second
- Pa – pascal
- MPa – megapascal

TGP reserves the right to change configurations without prior notice when deemed necessary for product improvement.

CONTENTS | Table of Contents

DATE | 01/12

FEATURES

- Almost any type of structural member can be used for a back mullion—from stainless steel to glulam beams
- Offers all the advantage of steel: larger free spans, narrower sight lines and improved thermal performance
- Narrow sight line of 1-3/4" (45 mm) or 2-3/8" (60 mm)
- No water penetration at 15 PSF pressure differential when tested to ASTM E283
- Air infiltration below 0.03 CFM /Ft² when tested to ASTM E33
- Variety of system depths
- Infill options up to 2"
- Stainless steel or anodized cover caps available
- Painted finishes in standard and custom choices
- Concealed fastener joinery creates smooth, monolithic appearance
- Shear block fabrication method
- Compatible with SteelBuilt Window & Door® Systems
- Silicone compatible glazing materials for long-lasting seals

OPTIONAL FEATURES

- Stainless steel cover caps
- Custom aluminum cover caps available

PRODUCT APPLICATIONS

- Ideal choice for tall span applications with no intermediate support
- Ideal for low to mid-rise applications where large glass and narrow sight lines are desired
- Coastal environments that benefit from the durability of stainless steel

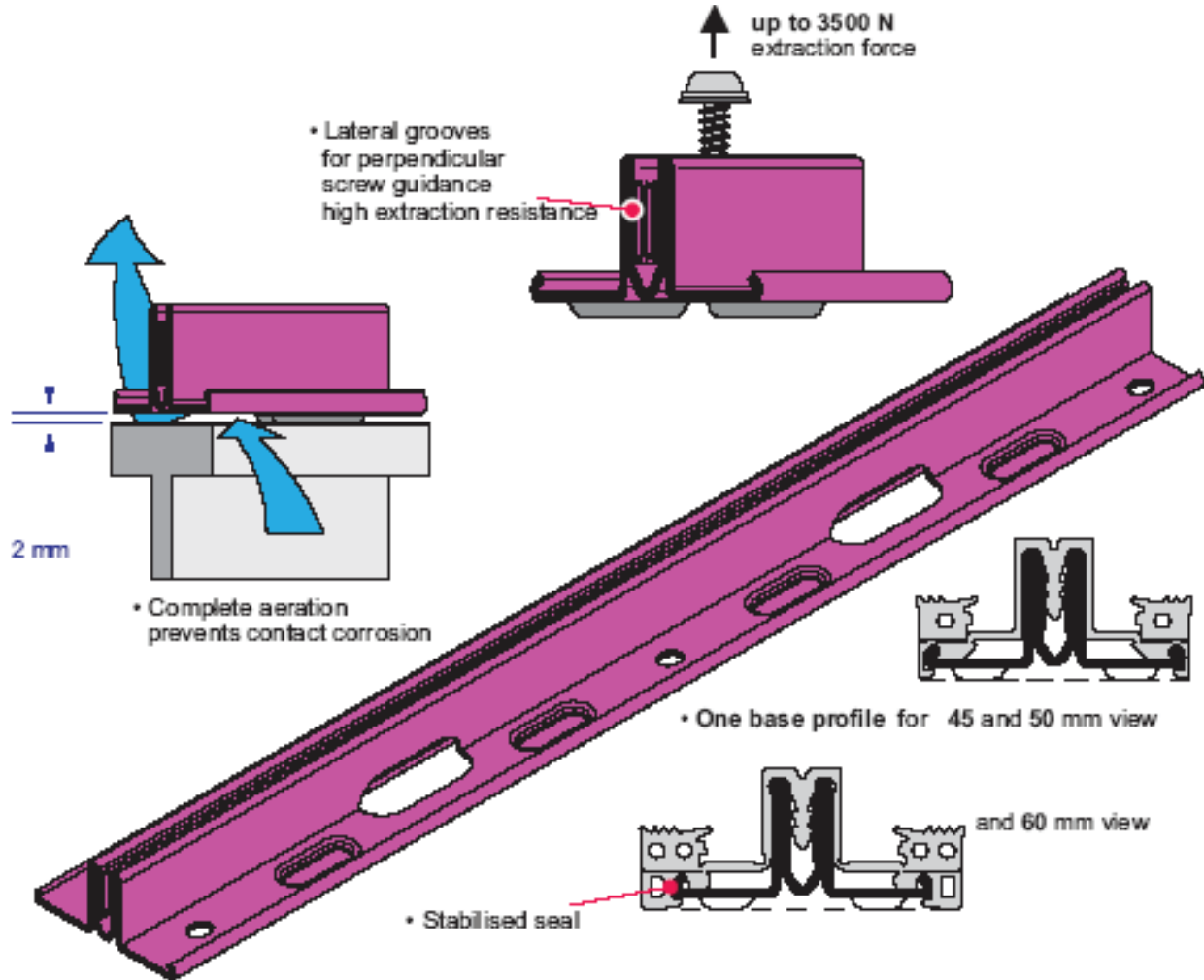

• For combination with all SteelBuilt mullion-transom façade systems

Welding fixation

Bolt fixation

Screw fixation

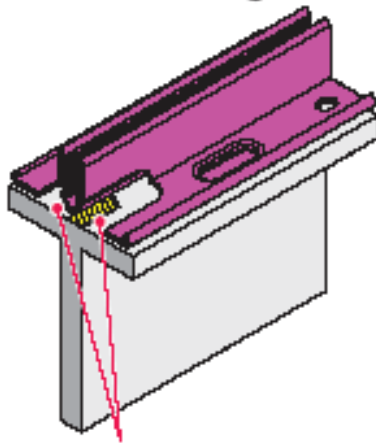

• Welding and corrosion protection through double opening

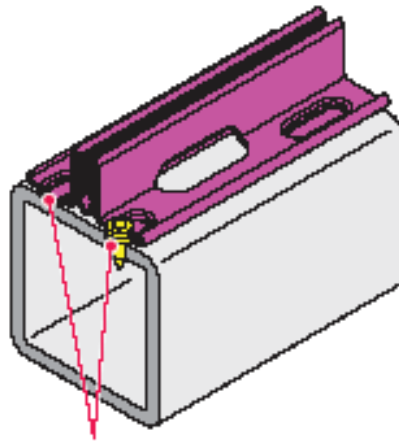

• Bolt head sunk in indented mark; seal insertion without problems

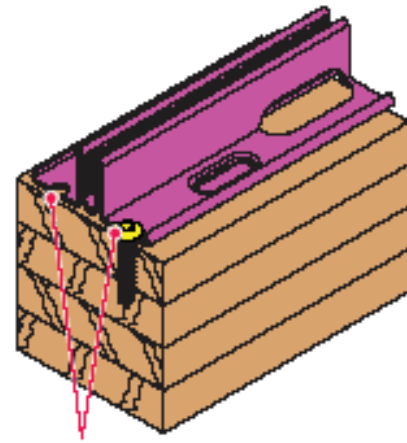

• Screw fixation through pre-punched holes

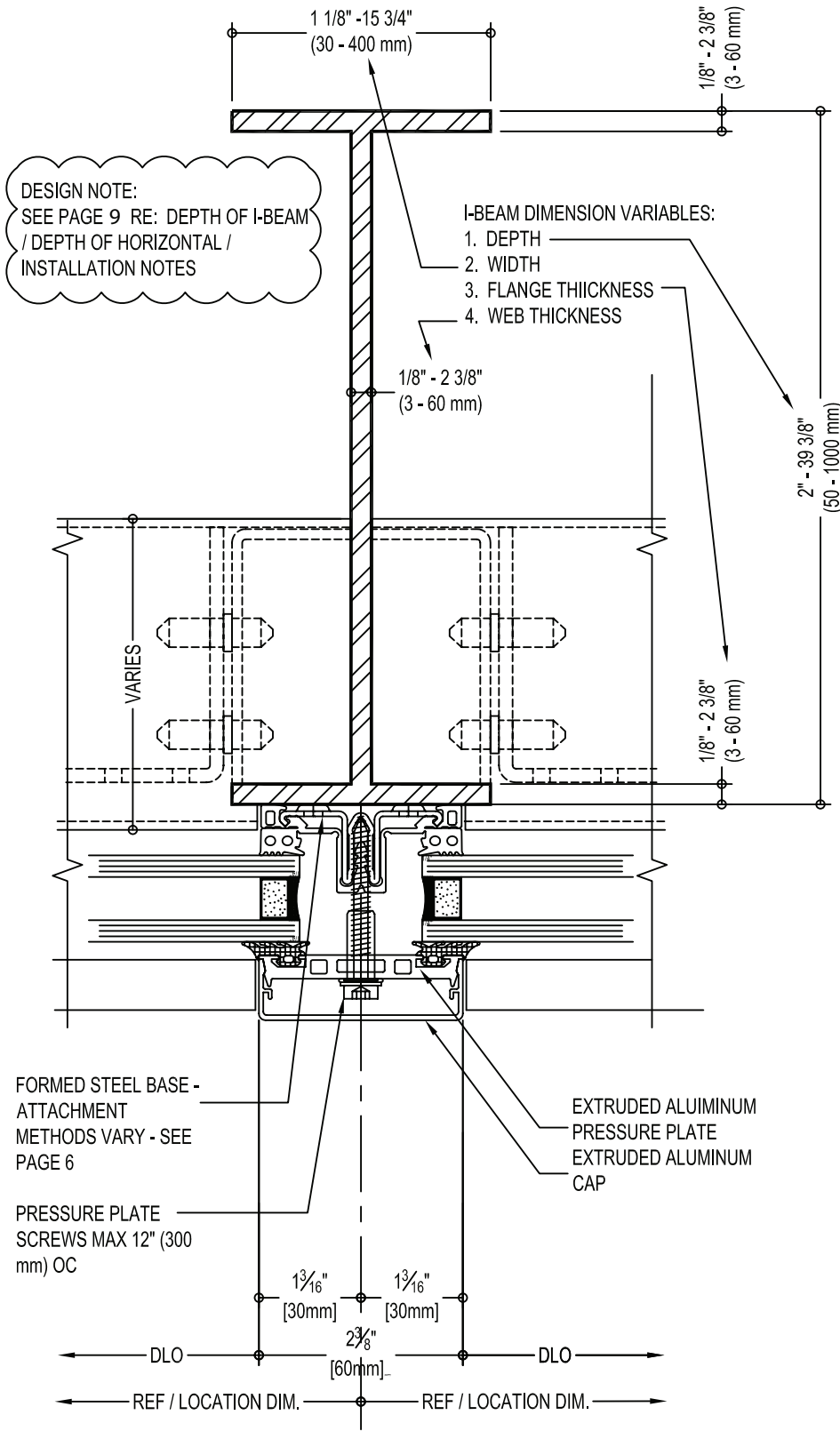

INFINITY I-BEAM OPTIONS

Materials:

- Carbon Steel
 - Blasted
 - Painted
- Stainless Steel
 - Blasted
 - Polished
 - Ground
 - Pickled

Member dimensions (depth, material thickness, etc.) dependent on span, load, and module dimensions.

Webs can be custom machined with

- Patterns
- Logos
- Other

Glazing:

- 1" thick (25 mm) shown
- 1/2" to 2" thick (12-50 mm) available
- Single, double, or triple glazing options available
- Structural silicone glazing

Face Dimension:

- 2 3/8" (60 mm) shown
- 1 3/4" (45 mm) and 2" (50 mm) available

Caps:

- Extruded aluminum, standard or custom caps, anodized or painted
- Stainless steel
- Depths vary by material, system width

- Any Infinity shape can be used
- SteelBuilt / rectangular tube system compatible
- Custom shapes available upon request

Infinity Mullions:

- Other shapes (custom) available upon request

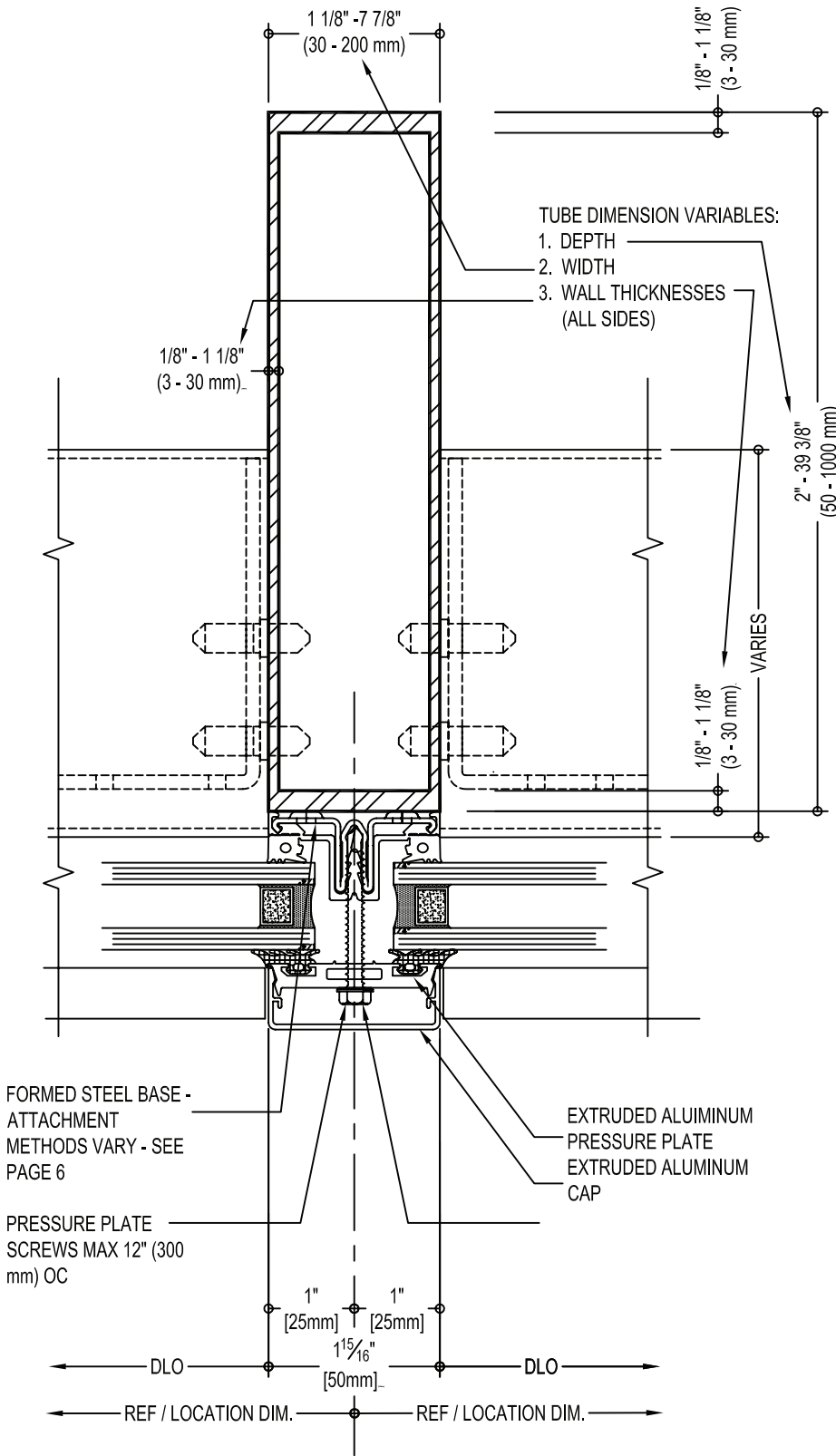

INFINITY TUBE PROFILE OPTIONS

Materials:

- Carbon Steel
 - Bead Blasted
 - Painted
- Stainless Steel
 - Bead Blasted
 - Polished
 - Ground
 - Pickled

Member dimensions (depth, material thickness, etc.) dependent on span, load, and module dimensions.

Sharp Corners:

- Radius less than 1/32" (0.5 mm)

Glazing:

- 1" thick (25 mm) shown
- 1/2" to 2" thick (12-50 mm) available
- Single, double, or triple glazing options available

Face Dimension:

- 2" (50 mm) shown
- 1 3/4" (45 mm) and 2 3/8" (60 mm) available

Caps:

- Extruded aluminum, standard or custom caps, anodized or painted
- Stainless steel
- Depths vary by material, system width

Horizontals:

- Any Infinity shape can be used
- SteelBuilt / rectangular tube system compatible
- Custom shapes available upon request

Infinity Mullions:

- Other shapes (custom) available upon request

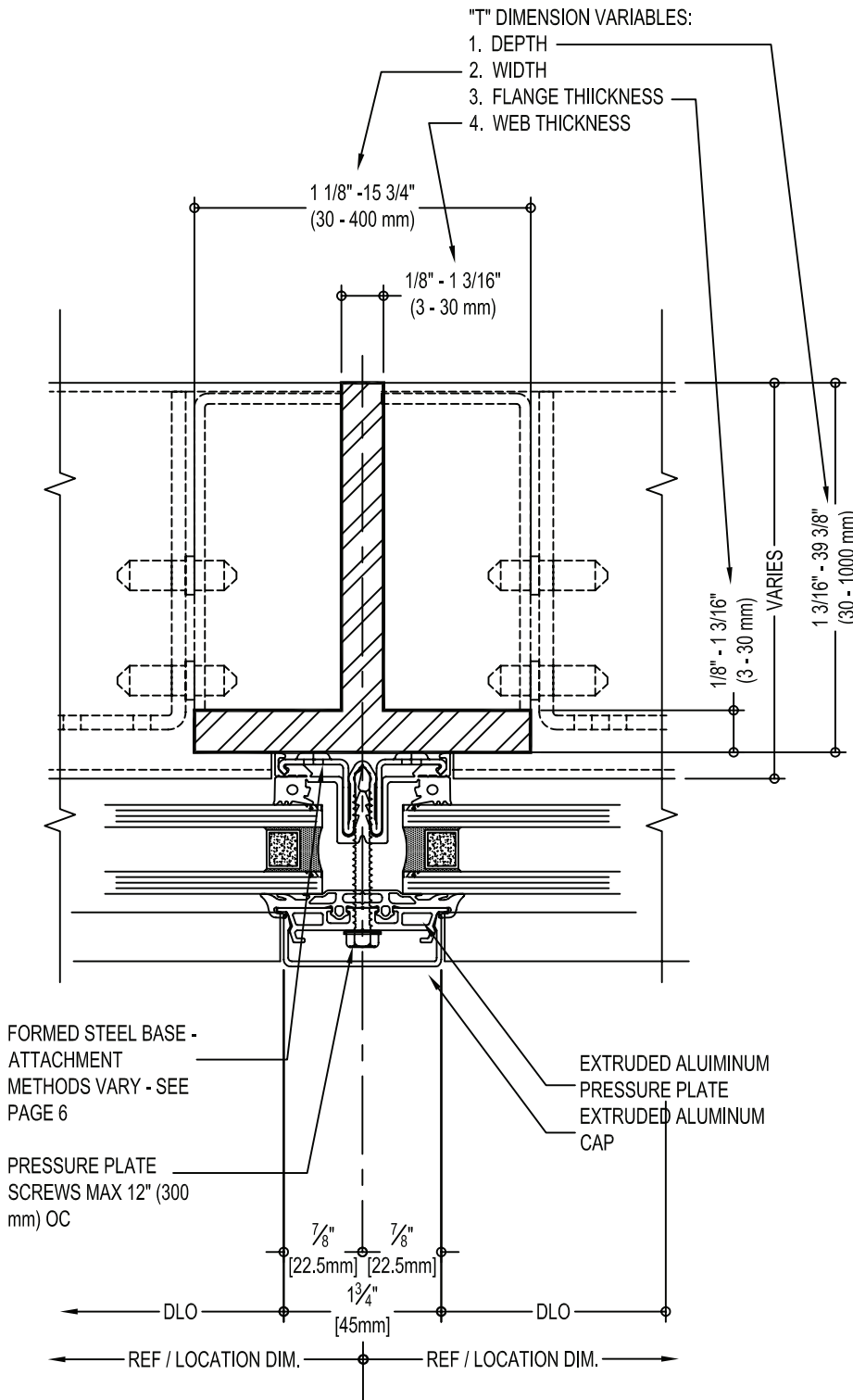

INFINITY T-PROFILE OPTIONS

Materials:

- Carbon Steel
 - Blasted
 - Painted
- Stainless Steel
 - Blasted
 - Polished
 - Ground
 - Pickled

Member dimensions (depth, material thickness, etc.) dependent on span, load, and module dimensions.

Webs can be custom machined with

- Patterns
- Logos
- Other

Glazing:

- 1" thick (25 mm) shown
- 1/2" to 2" thick (12-50 mm) available
- Single, double, or triple glazing options available

Face Dimension

- 1 3/4" (45 mm) shown
- 2" (50 mm) and 2 3/8" (60 mm) available

Caps:

- Extruded aluminum, standard or custom caps, anodized or painted
- Stainless steel
- Depths vary by material, system width

Horizontals:

- Any Infinity shape can be used
- SteelBuilt / rectangular tube system compatible
- Custom shapes available upon request

DESIGN NOTE:
SEE PAGE 9 RE: DEPTH OF TR
PROFILE / DEPTH OF HORIZONTAL /
INSTALLATION NOTES

"TR" DIMENSION VARIABLES:

1. DEPTH
2. WIDTH
3. FLANGE THICKNESS
4. DIA. OF ROUND
5. WEB THICKNESS

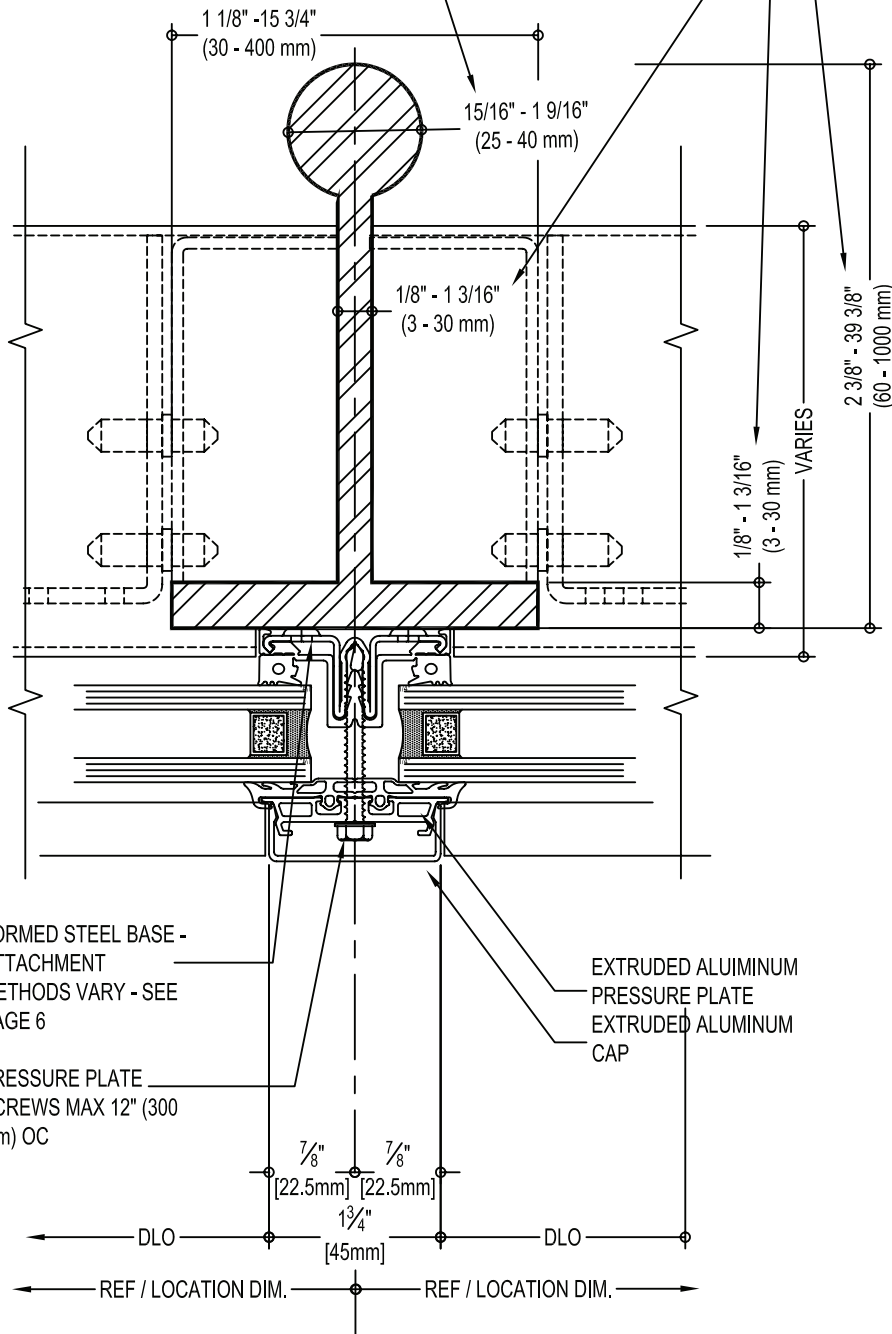

INFINITY TR-PROFILE OPTIONS

Materials:

- Carbon Steel
 - Blasted
 - Painted
- Stainless Steel
 - Blasted
 - Polished
 - Ground
 - Pickled

Member dimensions (depth, material thickness, etc.) dependent on span, load, and module dimensions.

Webs can be custom machined with

- Patterns
- Logos
- Other

Glazing

- 1" thick (25 mm) shown
- $\frac{1}{2}''$ to 2" thick (12-50 mm) available
- Single, double, or triple glazing options available

Face Dimension

- $1\frac{3}{4}''$ (45 mm) shown
- 2" (50 mm) and $2\frac{3}{8}''$ (60 mm) available

Caps:

- Extruded aluminum, standard or custom caps, anodized or painted
- Stainless steel
- Depths vary by material, system width

Horizontals:

- Any Infinity shape can be used
- SteelBuilt / rectangular tube system compatible
- Custom shapes available upon request

OTHER INFINITY PROFILES:

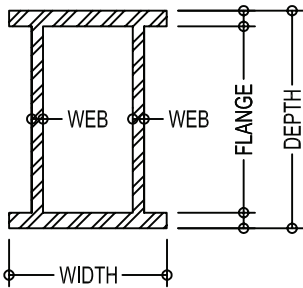

"H" DIMENSION VARIABLES:

1. DEPTH : 2" - 39 3/8" (50 -1000 mm)
2. WIDTH: 1 3/16" - 15 3/4" (30 - 400 mm)
3. FLANGE, WEB THICKNESSES:
1/8" - 1 3/16" (3 - 30 mm)

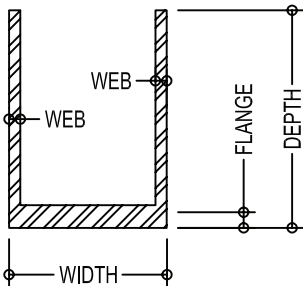

"U" DIMENSION VARIABLES:

1. DEPTH : 1 9/16" - 39 3/8" (40 -1000 mm)
2. WIDTH: 1 9/16" - 7 7/8" (40 - 200 mm)
3. FLANGE, WEB THICKNESSES: 1/8" - 1 3/16" (3 - 30 mm)

INFINITY PROFILE OPTIONS

Framing Options:

Descriptions below are suggested options for framing as may be developed by design professionals. TGP is available to assist the design professional with any questions regarding attachment or support of SteelBuilt Curtainwall Infinity™ System glazing materials not furnished by TGP.

Method of attachment of Infinity glazing materials to other framing options is permitted. This work is typically completed by the installer in the field.

TGP does not typically design, furnish, or finish these materials. Design of these members is not by TGP, and should be verified by registered, licensed professional engineers or architects.

Glue-laminated wood: any shape, size, and profile

Steel or aluminum:

- Hot rolled steel or extruded tubes, rounds, or structural shapes
- Truss assemblies
- Structural steel framing

Sloped or vertical framing (with safety glazing) is permitted.

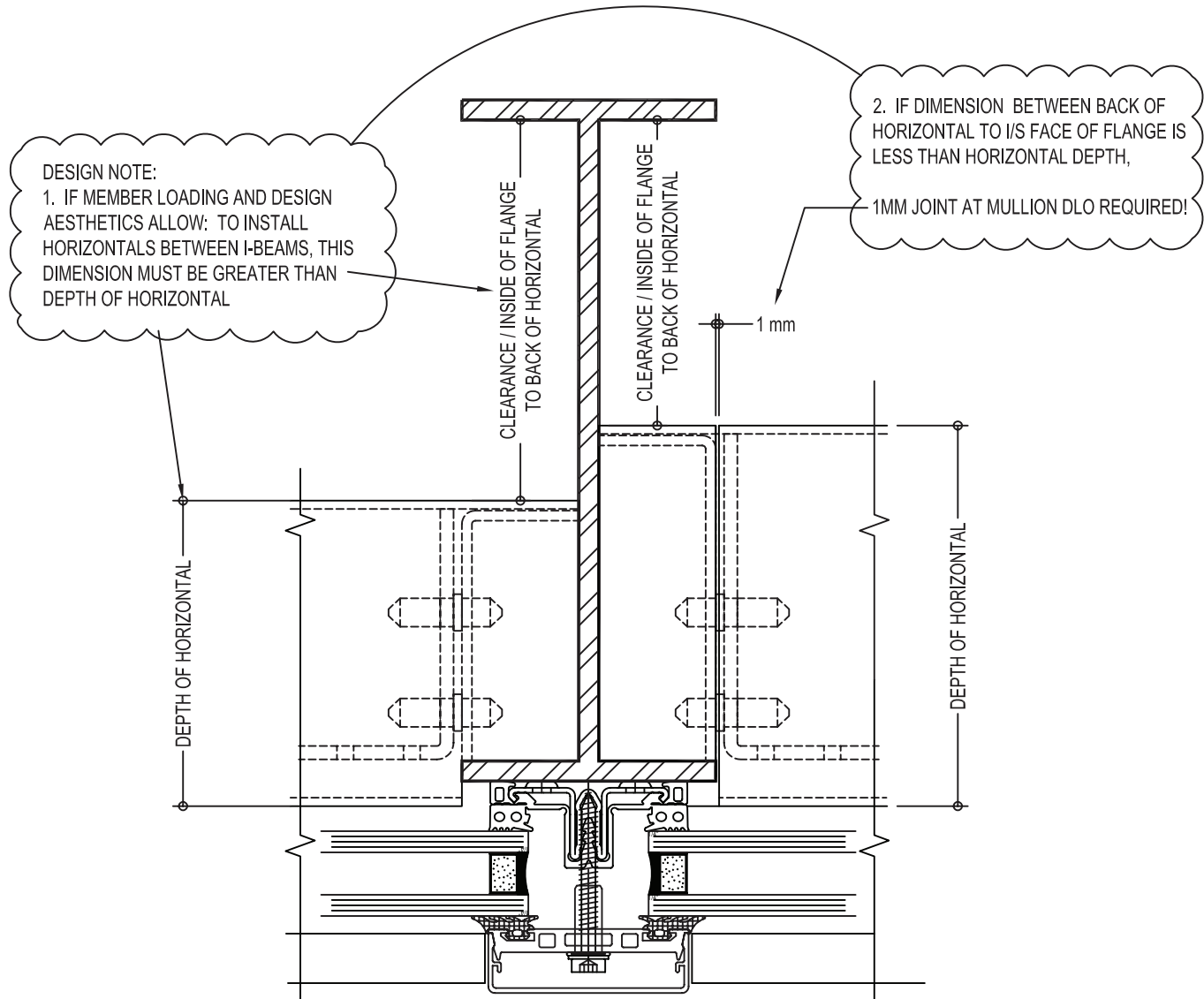

DEPTH OF VERTICAL / INSTALLATION OF
STEELBUILT HORIZONTALS AT
I-BEAM , TR PROFILES

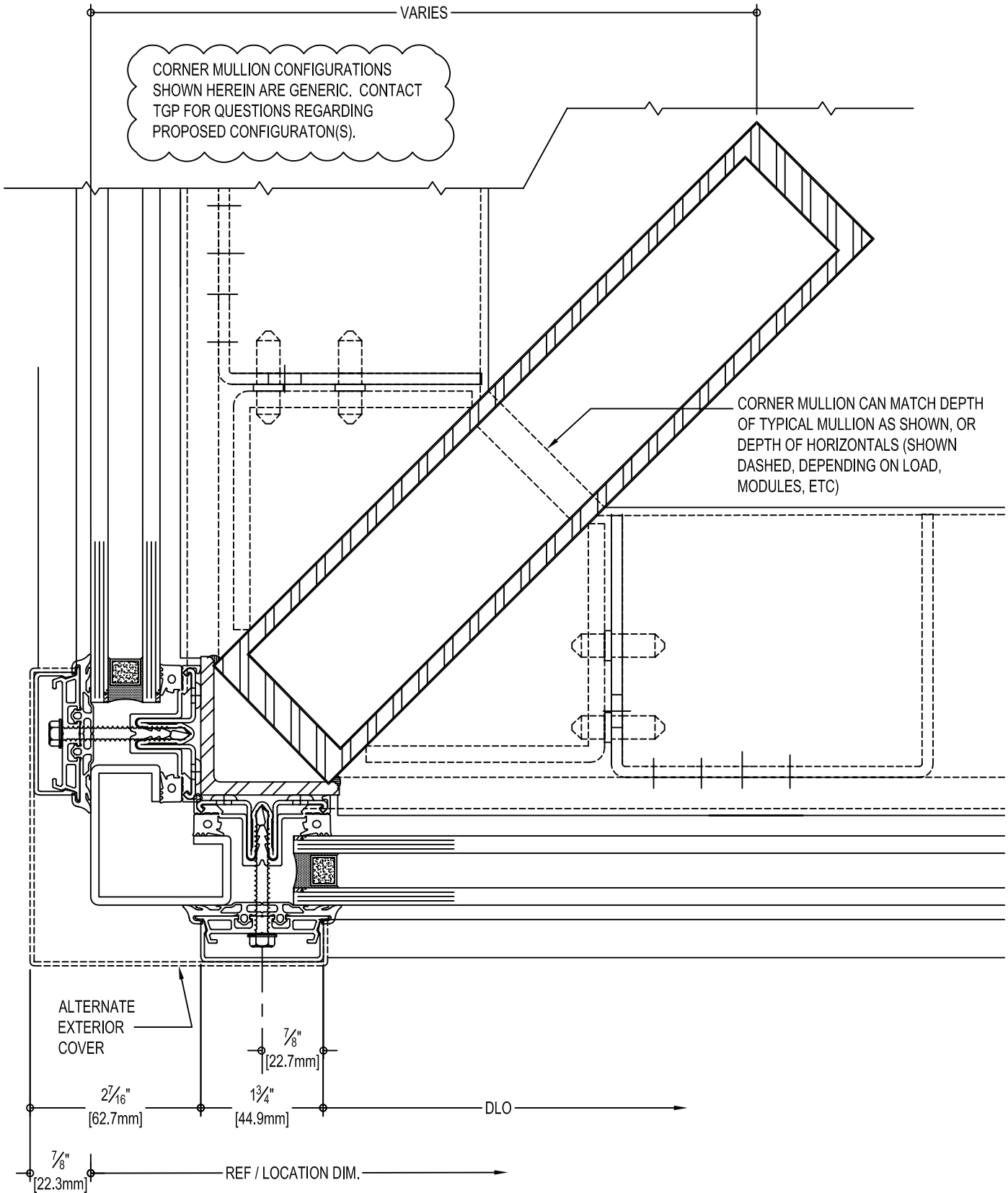

INFINITY CORNER OPTIONS

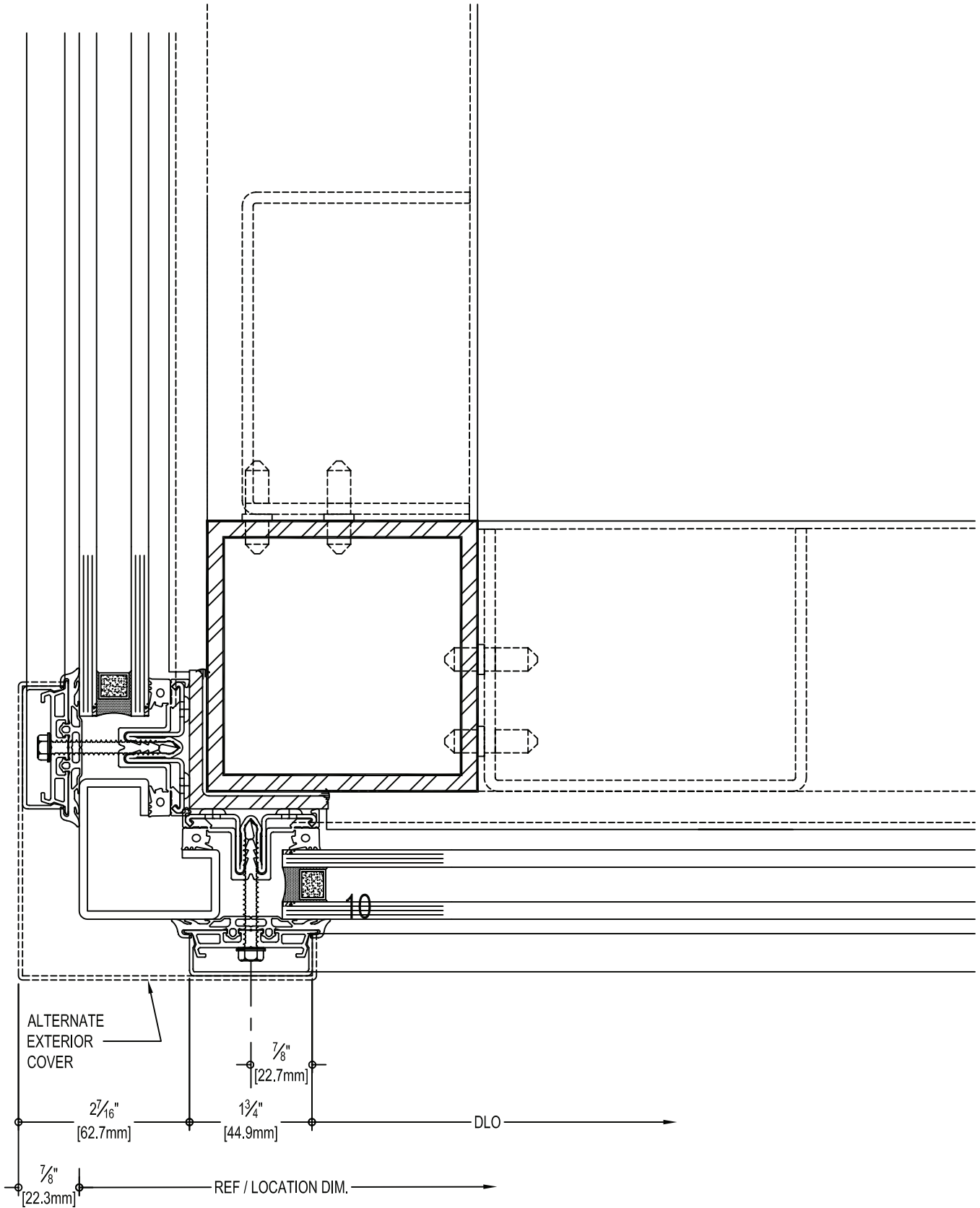

INFINITY CORNER OPTIONS

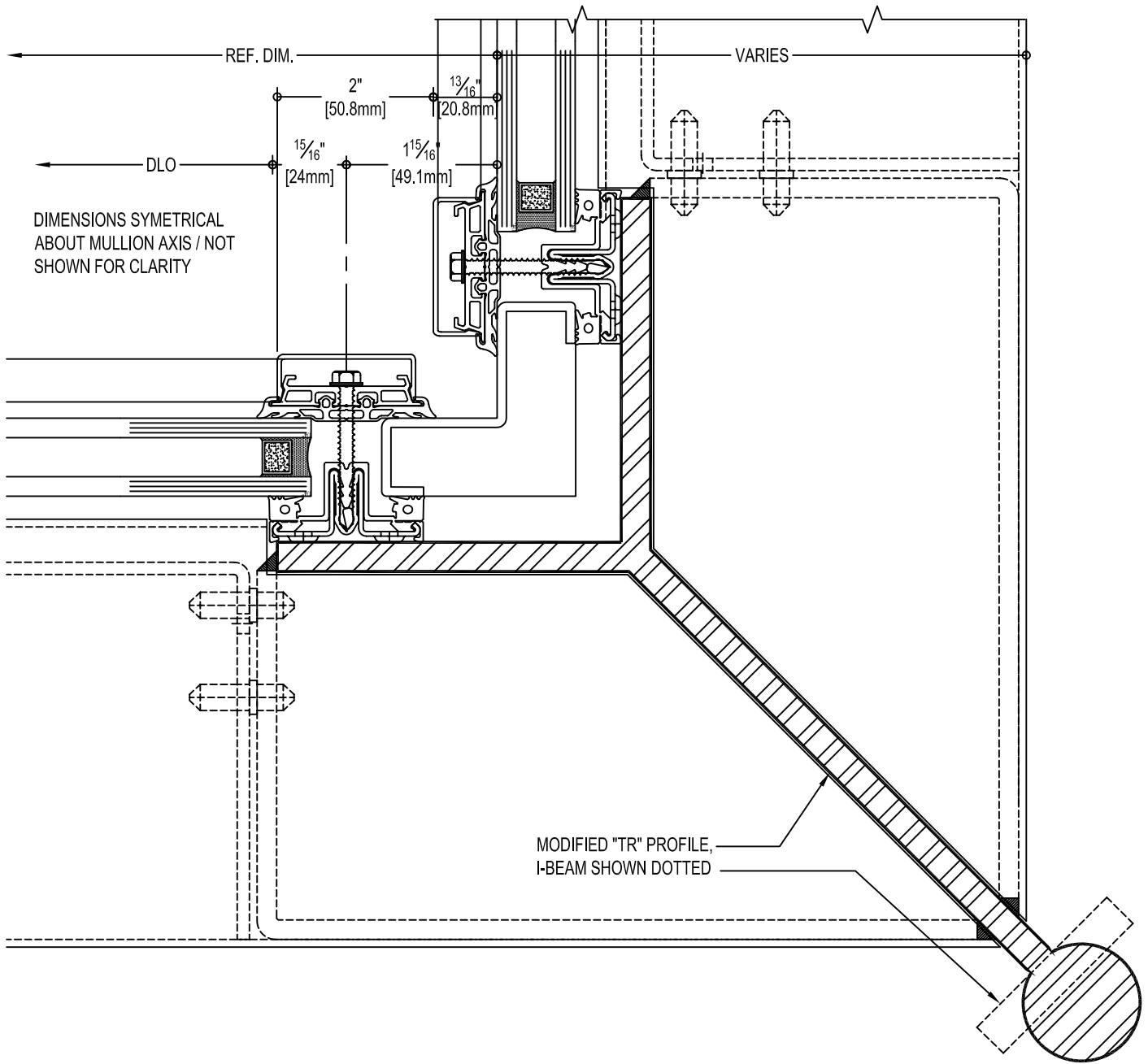

INSIDE CORNER OPTIONS

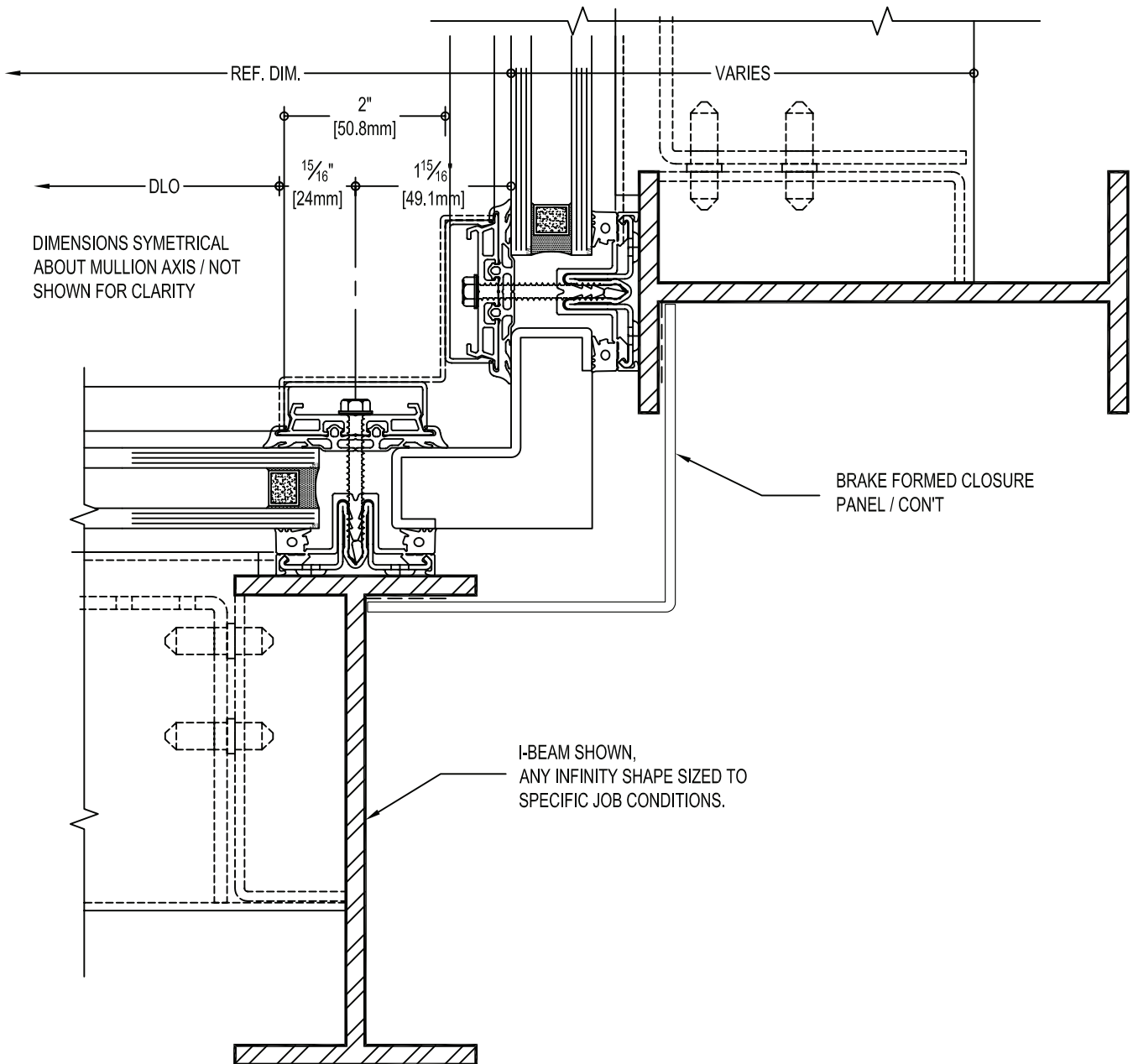

INSIDE CORNER OPTIONS

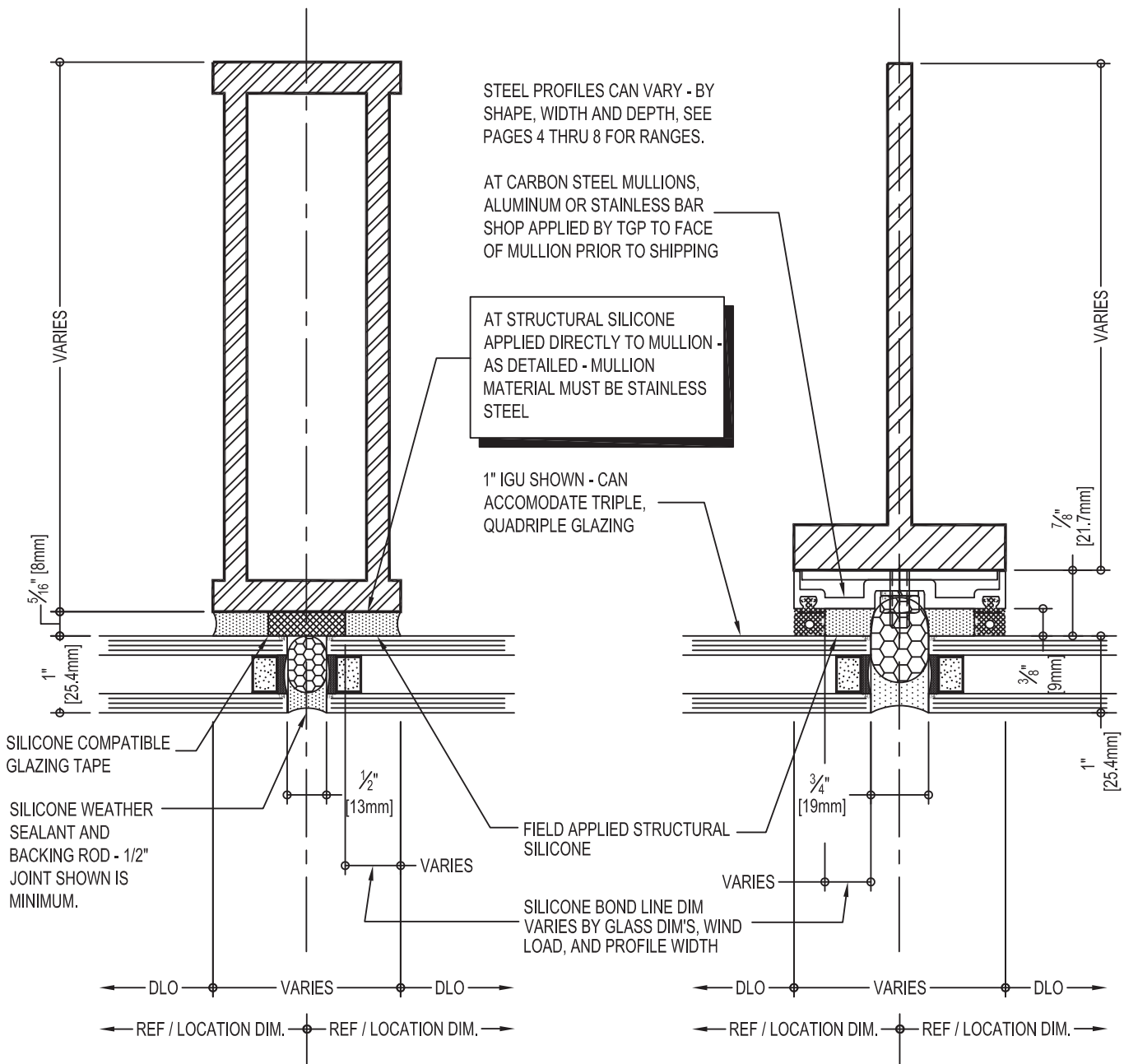

STRUCTURAL SILICONE GLAZING / MULLION

CORNER MULLION CONFIGURATIONS SHOWN HEREIN ARE GENERIC. CONTACT TGP FOR QUESTIONS REGARDING PROPOSED CONFIGURATON(S).

CONFIGURATION AT BACK OF MULLION CAN VARY:
 1. BRAKE METAL TO MATCH MULLION MATERIAL AS SHOWN
 2. PER STANDARD PROFILES - REF PREVIOUS DETAILS

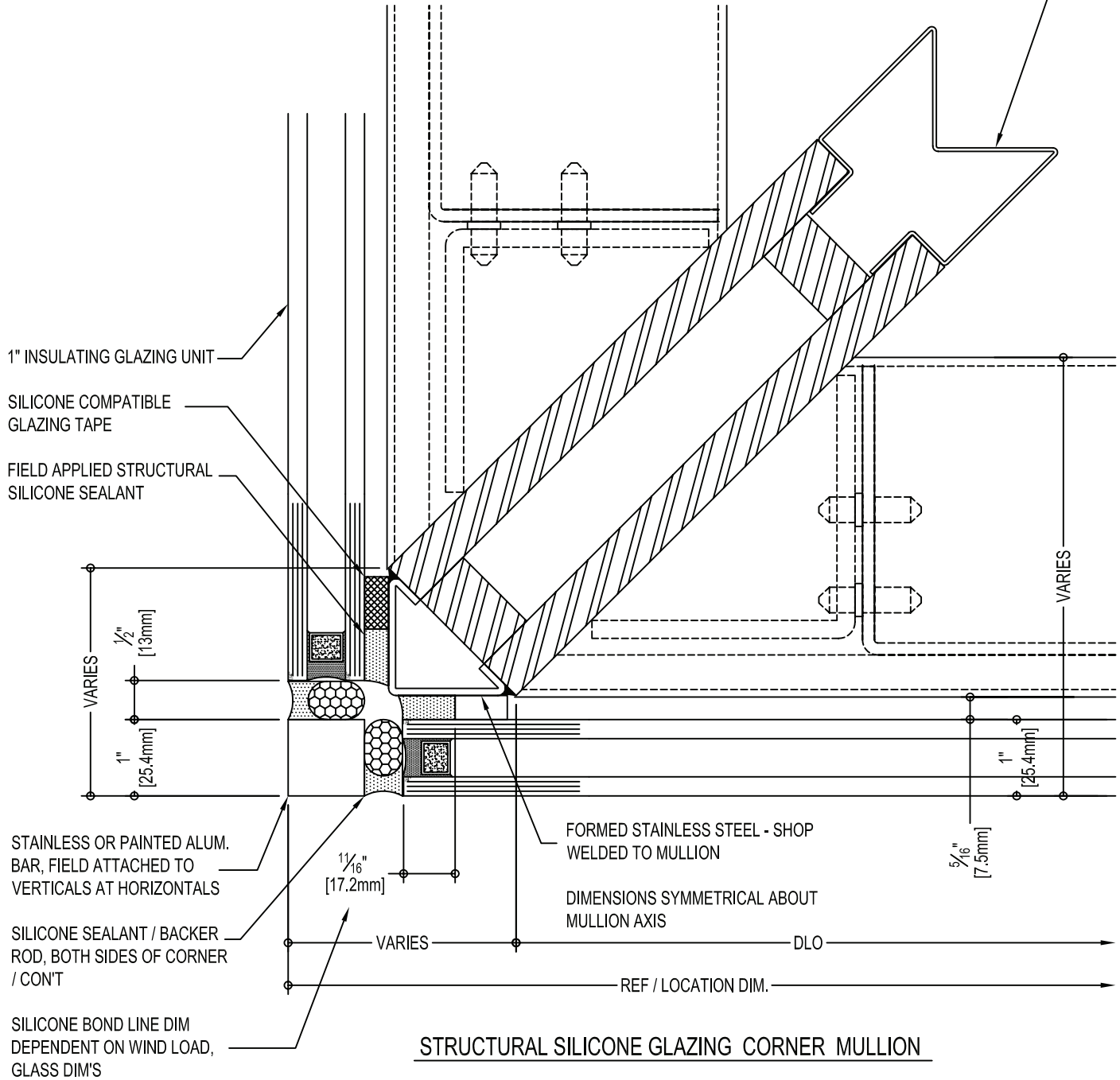

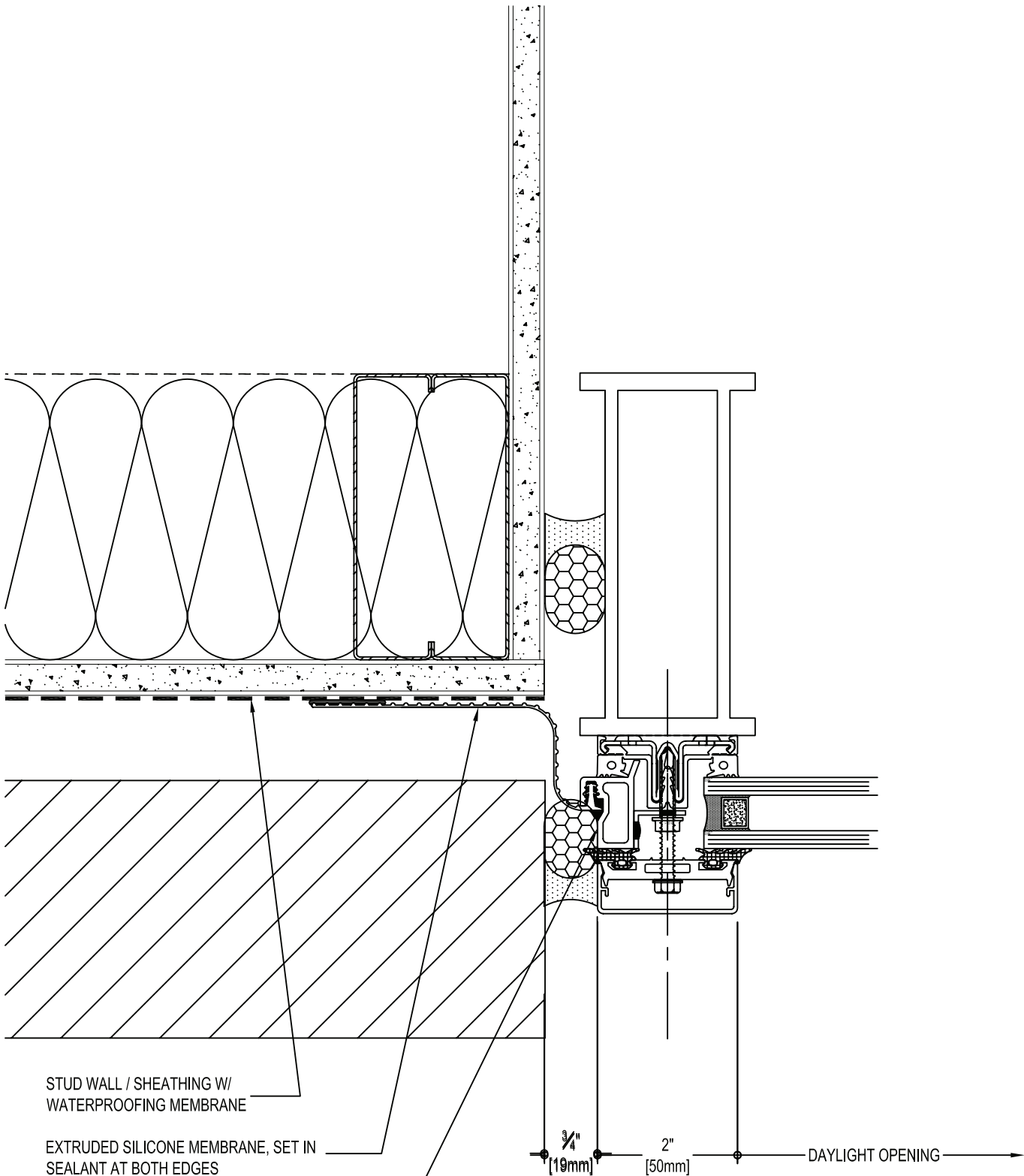

STUD WALL / SHEATHING W/
WATERPROOFING MEMBRANE

EXTRUDED SILICONE MEMBRANE, SET IN
SEALANT AT BOTH EDGES

EXTRUDED ALUMINUM / ALODINE FINISH
(MIN), SUPPLIED LOOSE BY TGP
FOR FIELD INSTALLATION

$\frac{3}{4}$ " [19mm] 2" [50mm] DAYLIGHT OPENING

ALTERNATE PERIMETER

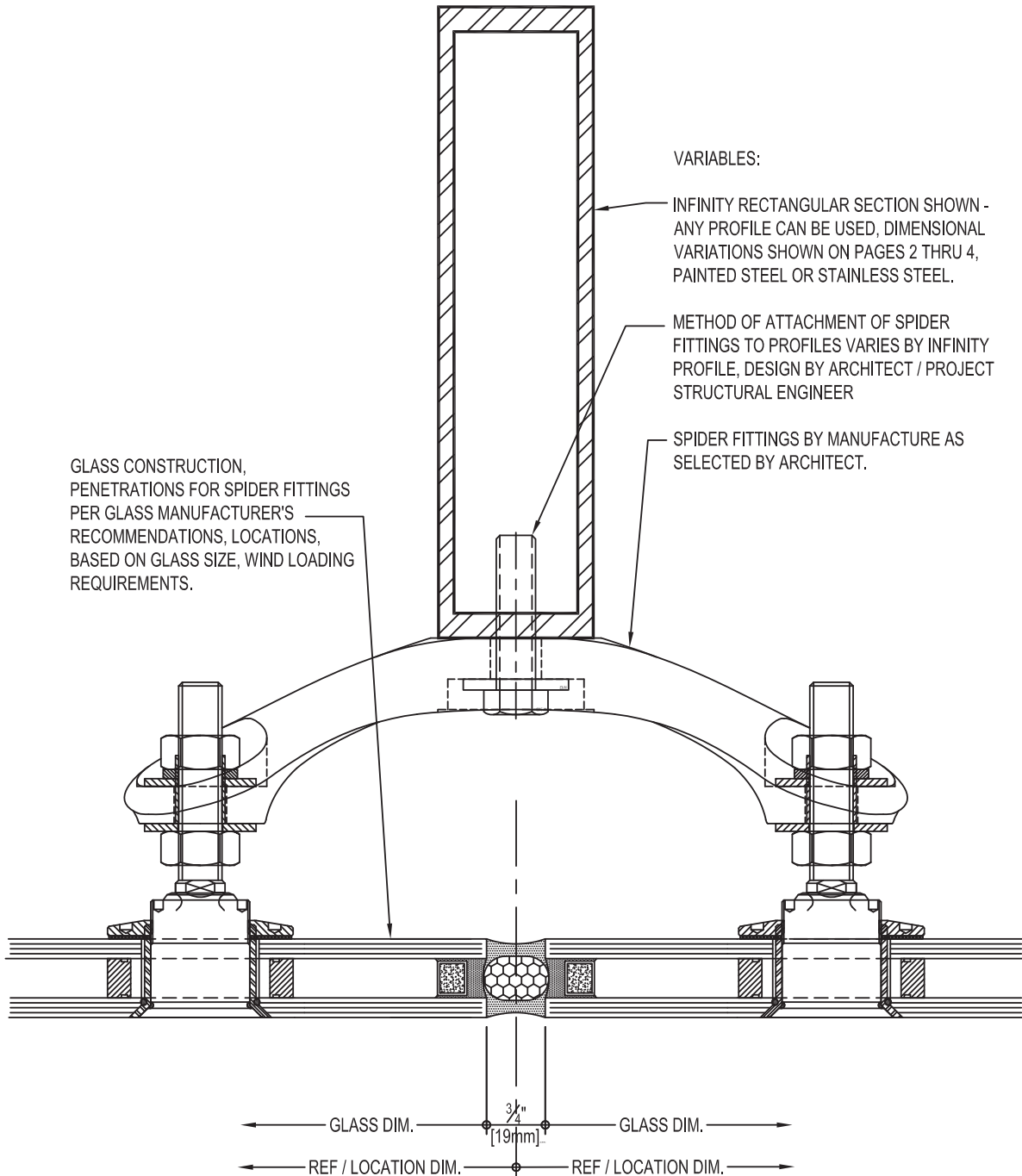

INFINITY PROFILE OPTIONS

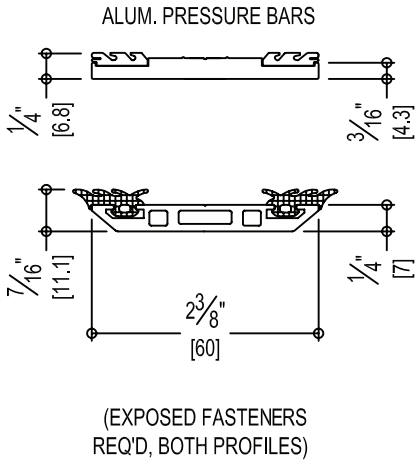
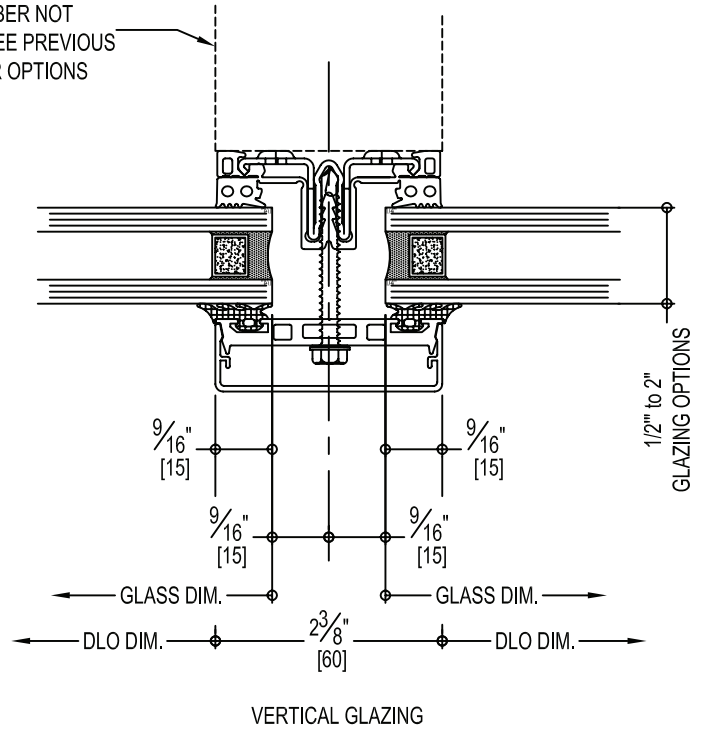
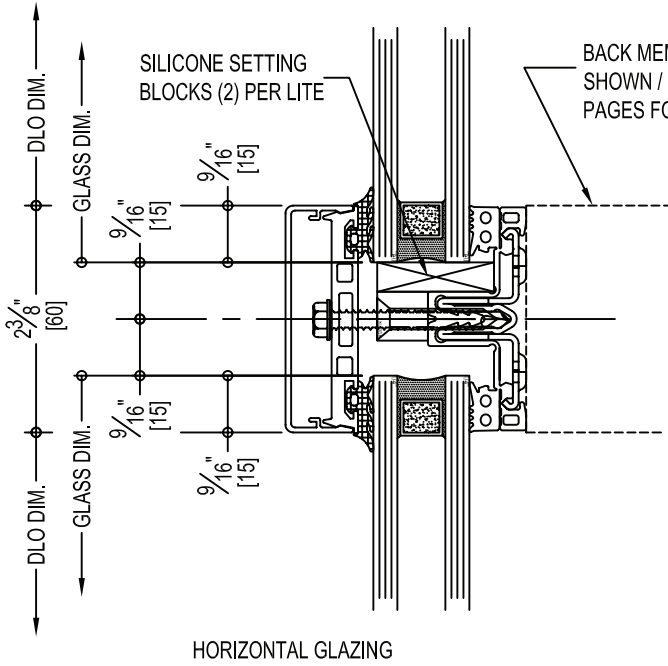

STAINLESS STEEL PRESSURE PLATES AND COVER CAPS

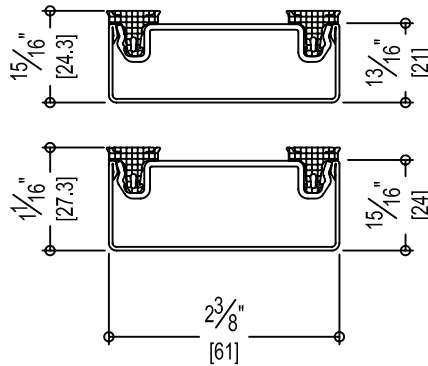

ALUM. PRESSURE PLATES, ALUM. COVER CAPS

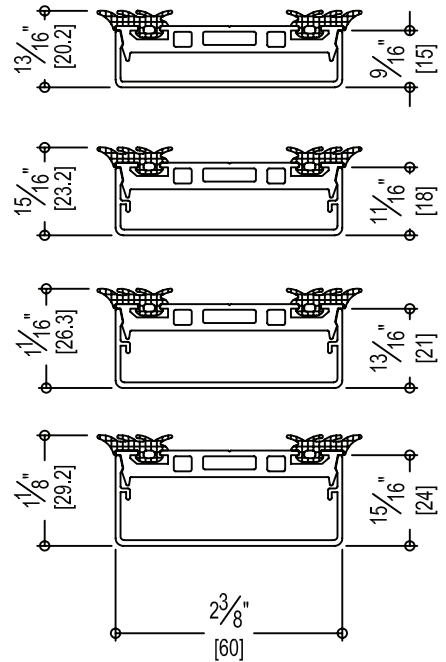

60 mm COVERS, GLAZING

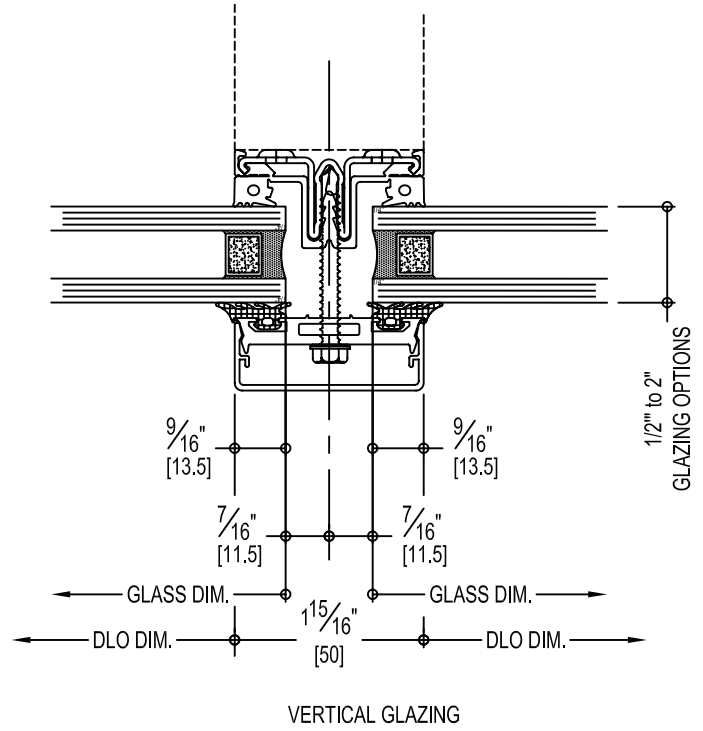
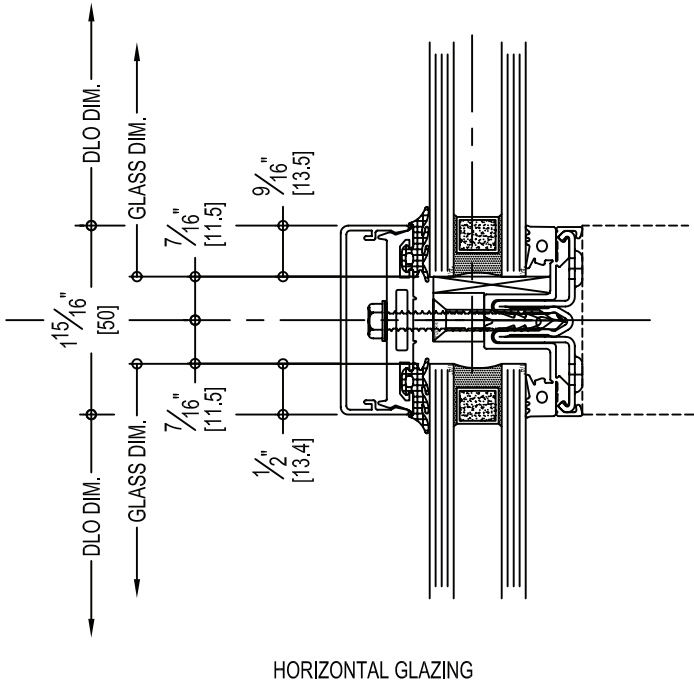

COVER CAP, PRESSURE PLATE & GASKET

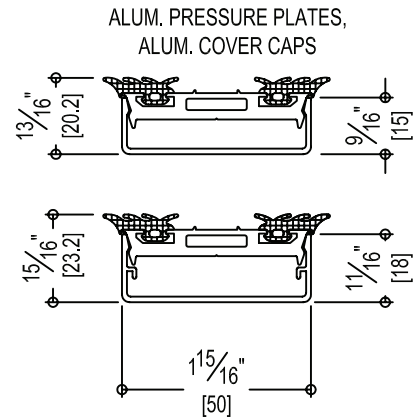
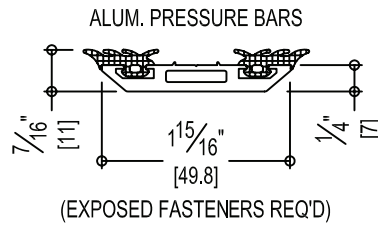

50 mm COVERS, GLAZING

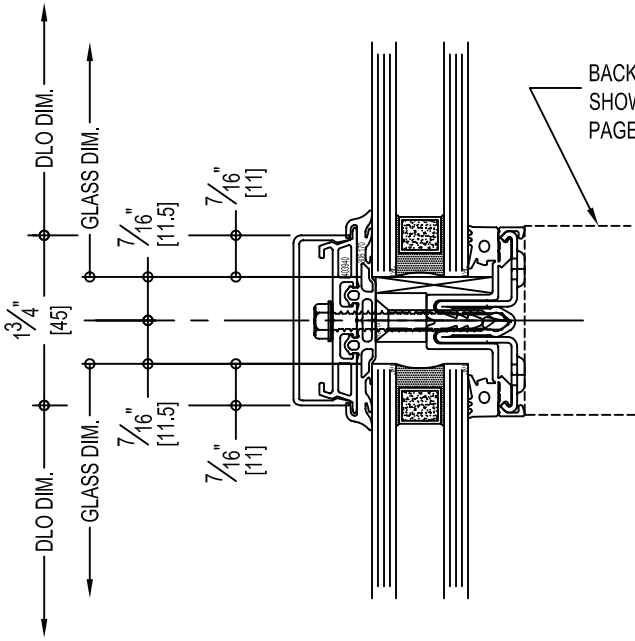

HORIZONTAL GLAZING

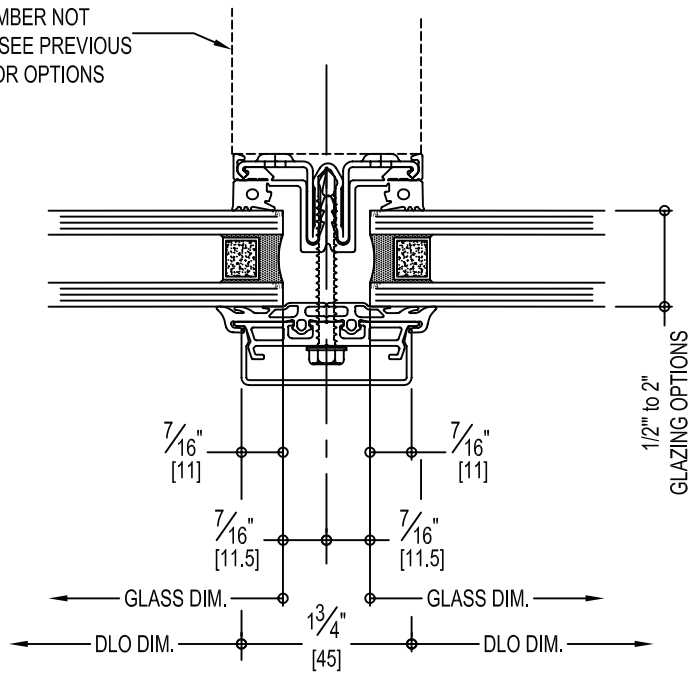

VERTICAL GLAZING

COVER CAP, PRESSURE PLATE & GASKET

ALUM. PRESSURE PLATES,
STAINLESS STEEL COVER CAPS

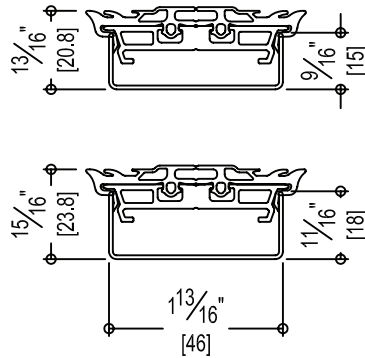

ALUM. PRESSURE PLATES,
ALUM. COVER CAPS

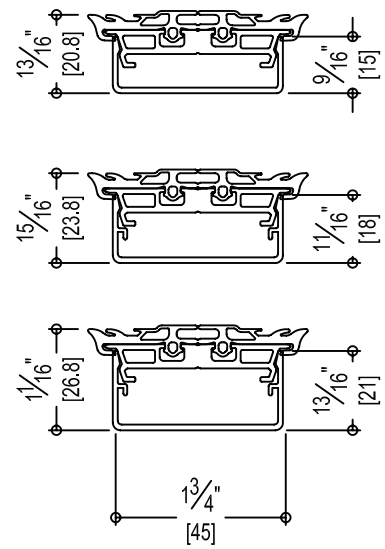

45 mm COVERS, GLAZING